

MYLOCOSOUND

PREMIUM RECORDED SOUND FOR INDUSTRIAL AND LIGHT LOCOMOTIVES POWERED BY DIESEL AND GAS

1. OVERVIEW

- Easy installation using screw terminals with no soldering.
- Uses a TV remote control to adjust the sounds to match the prototype loco.
- Uses recorded engine sounds for starting, tickover, in motion and shut down.
- Six vibrant horns including two tone horn and a Klaxon.
- American bell.
- Full remote control of the horns, airbrake, guard's whistle and "All aboard".
- Optional airbrake release and brake squeal.
- For track powered DC or battery powered railways.
- Measures 55mm x 33mm x 11mm.

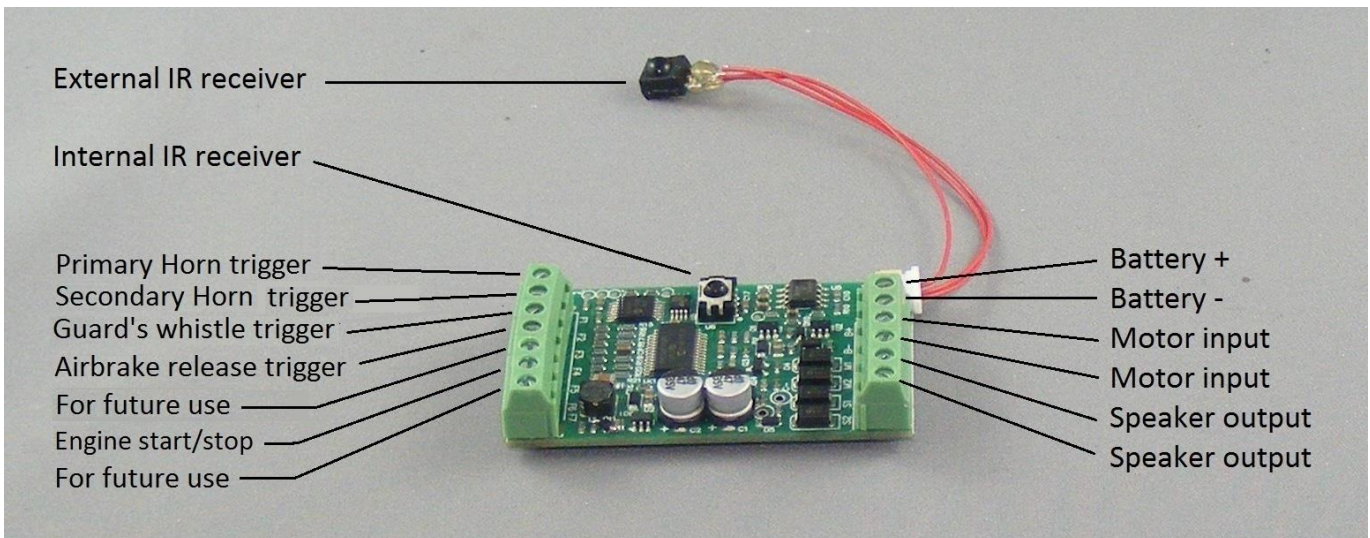

2. CONTENTS

The soundcard generates synthesised sound which is adjustable to reproduce the sounds of most light diesel locos. The terminal connections on the right are necessary for the soundcard to generate diesel sounds which vary with the loco speed and load. The terminal connections on the left trigger the various sounds where the locomotive controller has the appropriate outputs available. The trigger terminals are labelled F1 to F7 and are referred to by these labels in these instructions. For example, "Triggering F1" means to close a contact between the F1 terminal and the Battery negative terminal.

Sounds can also be triggered by a Sony infra-red TV remote control which can be purchased locally. Low cost, universal, TV remote controls are available from most consumer electronics stores and need to be set to Sony coding to work with the soundcard. Although it can be used over short distances when running in the garden, the remote control is intended mainly for the adjustment and testing of sounds.

The remote control communicates with the soundcard via two infra-red receivers. One



is located on the soundcard and the other is on a flying lead which allows it to be fixed to any external surface of the loco. Adjustments to the sounds can then be made without taking the loco apart to access the soundcard.

3. SPEAKERS AND SOUND QUALITY

The soundcard requires an 8 ohm loudspeaker which is not included. Your choice of speaker is highly important because it determines the quality of the sound produced. A power output of at least one watt is recommended.



Fosworks can supply a wide range of speakers which we have tested for compatibility and which will fit in your model.



For a better quality sound and more volume, the speaker needs to be baffled. That means that it needs to be built into the front face of an airtight box so that sound is heard only from the front of the speaker and none from the back. The plastic top of a spray paint can is good for making a baffle as shown in the diagram. Speakers can be connected to the terminals either way around.

Important Notes

The soundcard is designed for outdoor use and may not work correctly under bright incandescent lights on a workbench. LED lights are okay.

The soundcard is in a "sleep" mode when not in use. Connecting it to power at the B+ and B- terminals will not wake it up. It must also be connected to a motor at the M1 and M2 terminals as well. The small voltage it sees at the motor will wake it up and it will then stay awake for as long as it has power.

4. INSTALLING THE SOUND CARD IN A TRACK POWERED LOCOMOTIVE, DC OR DCC

The soundcard is suitable for use on analogue DC track powered railways on which the following wiring diagram should be used:

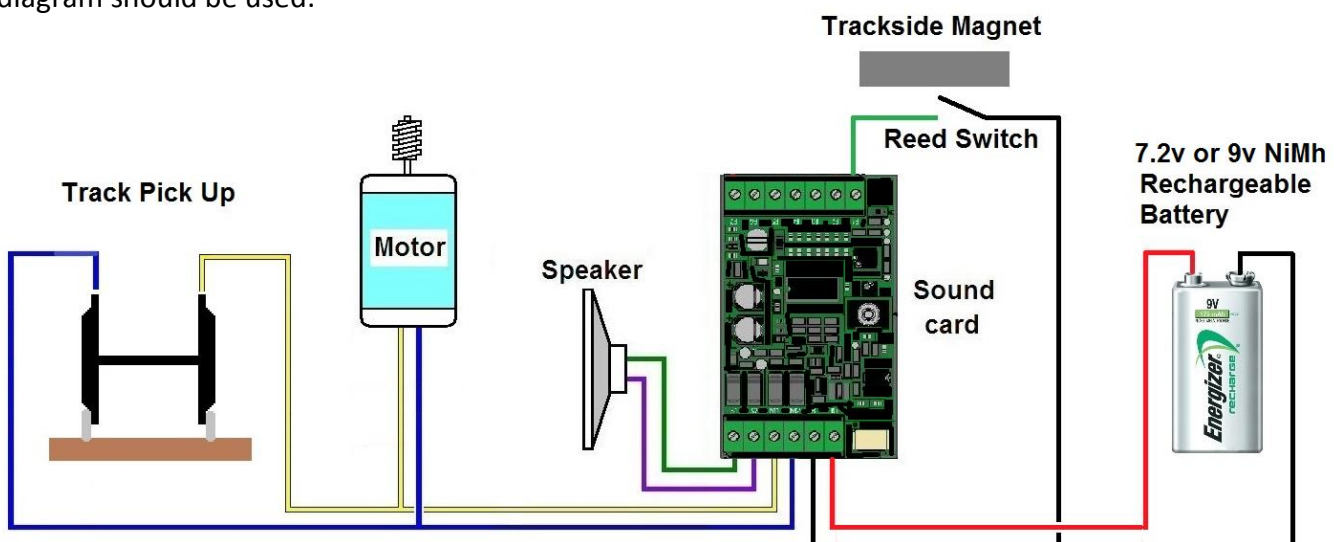

The wiring diagram below shows the connections for the DC jumper board in a Bachmann locomotive.

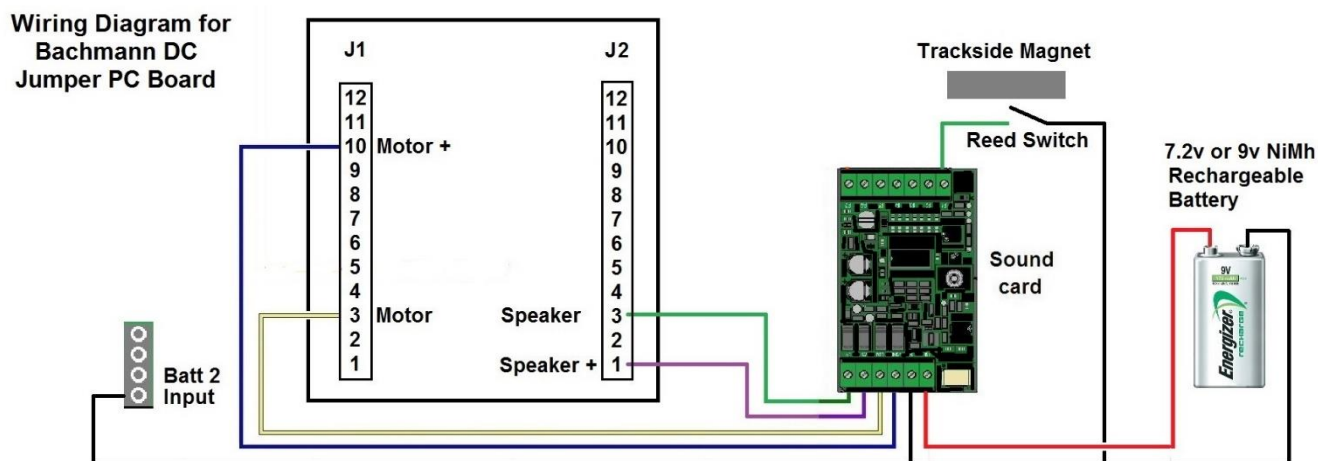

On DCC track powered railways in locomotives using a basic decoder, the wiring is a little different:

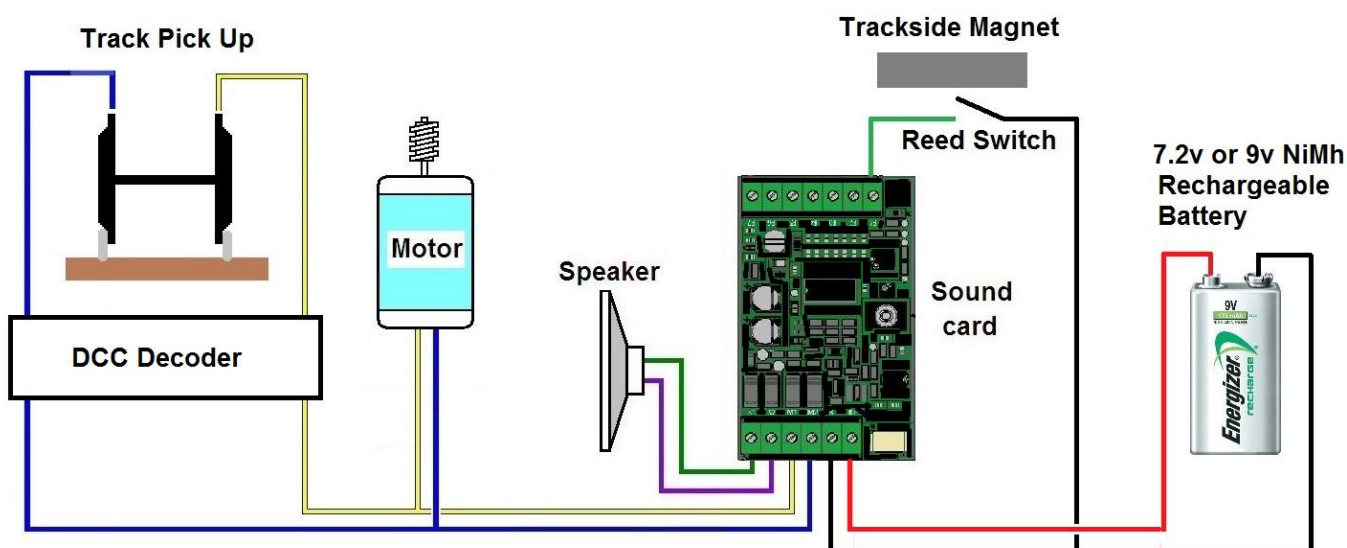

When the motor voltage is below seven volts it is insufficient to power the soundcard. Therefore a 9v volt PP3 or a 7.2v cordless phone battery is used to drive the soundcard and produce sound when the loco is static or moving slowly. This battery will be automatically recharged whenever the motor voltage is at about 1.8 volts higher than the battery voltage so there should never be a need to remove the battery for recharging. However, the battery must be a Nickel Metal Hydride type; Lithium and Nickel Cadmium batteries must not be used.

If your loco has a motor on/off switch, it can be used to recharge the battery while the loco is stopped. Just switch off the motor and turn up the track voltage to at least 11VDC.

Another option is to fit a recharging socket so that the support battery can be recharged, using an external battery charger, without removing the battery from the loco. We recommend using a three pin, panel mounted DC power socket which, when wired as shown, isolates the soundcard when the charger is plugged in.

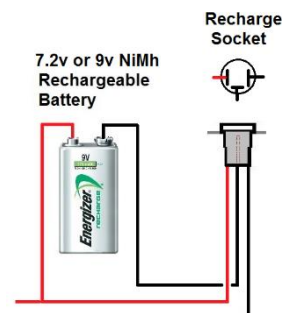

On analogue DC layouts which have pure DC controllers (as opposed to PWM controllers) you may need to give the throttle a bit of a tweak to start the sound. On those layouts, the sound will automatically turn

off after one minute of inactivity and another tweak will turn it back on. With the more common PWM controllers and with DCC the sound will turn on automatically and stay on.

When the loco is removed from the track the soundcard will go into a “sleep” mode to preserve the battery charge. A fully charged battery should retain charge for over a year.

Because most DC controllers do not have function buttons, an alternative way of triggering the horn, bell and other sounds needs to be found. The options are:

1. You can set the horn to sound automatically three times a minute when the train is running. Other sounds can also be triggered automatically. This is described in section 8.
2. You can connect the soundcard horn trigger to a reed switch which you mount on the bottom of the loco. Then install magnets in the track where you want the horn to sound eg. at the approaches to a level crossing. The horn will then sound briefly as the loco crosses each magnet.
3. Use the remote control, supplied with the soundcard, to trigger all the sounds as described in section 8. However, infra-red remote controls are not designed for long distance use outside. On an overcast but bright day, the remote control, powered by AA or AAA batteries will probably operate up to three metres away.

Any combination, or all, of these methods can be used.

With DCC, the soundcard is not a decoder and cannot trigger sounds directly from the controller. Therefore the above methods are used to trigger the sounds. Some decoders have a servo output which can be used to trigger sounds from the controller buttons by using a servo switch. They may also have a constant DC power output which can replace the battery if it is in the voltage range 8 to 24 volts. These connection options are shown below:

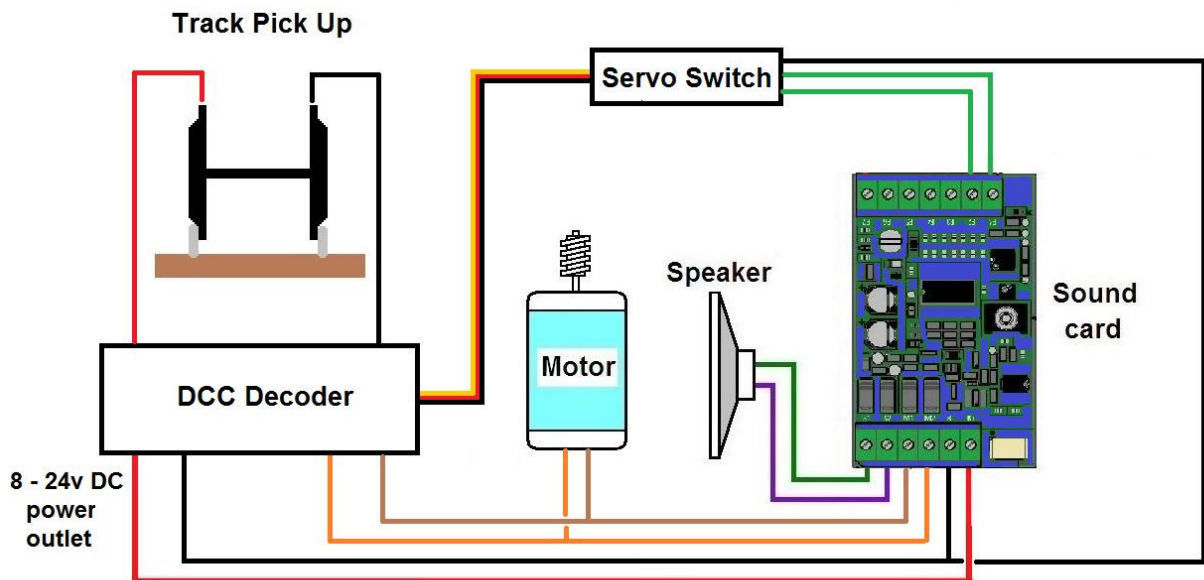

Many decoders also have function outputs which can be used to trigger sounds. However, this is technically difficult and you should only attempt it if you are very familiar with your decoder and the setting of CVs.

Now continue reading at section 6.

5. INSTALLING THE SOUND CARD IN A BATTERY POWERED LOCOMOTIVE OR RAILCAR

The wiring diagram below shows a typical installation for common types of battery powered radio control systems.

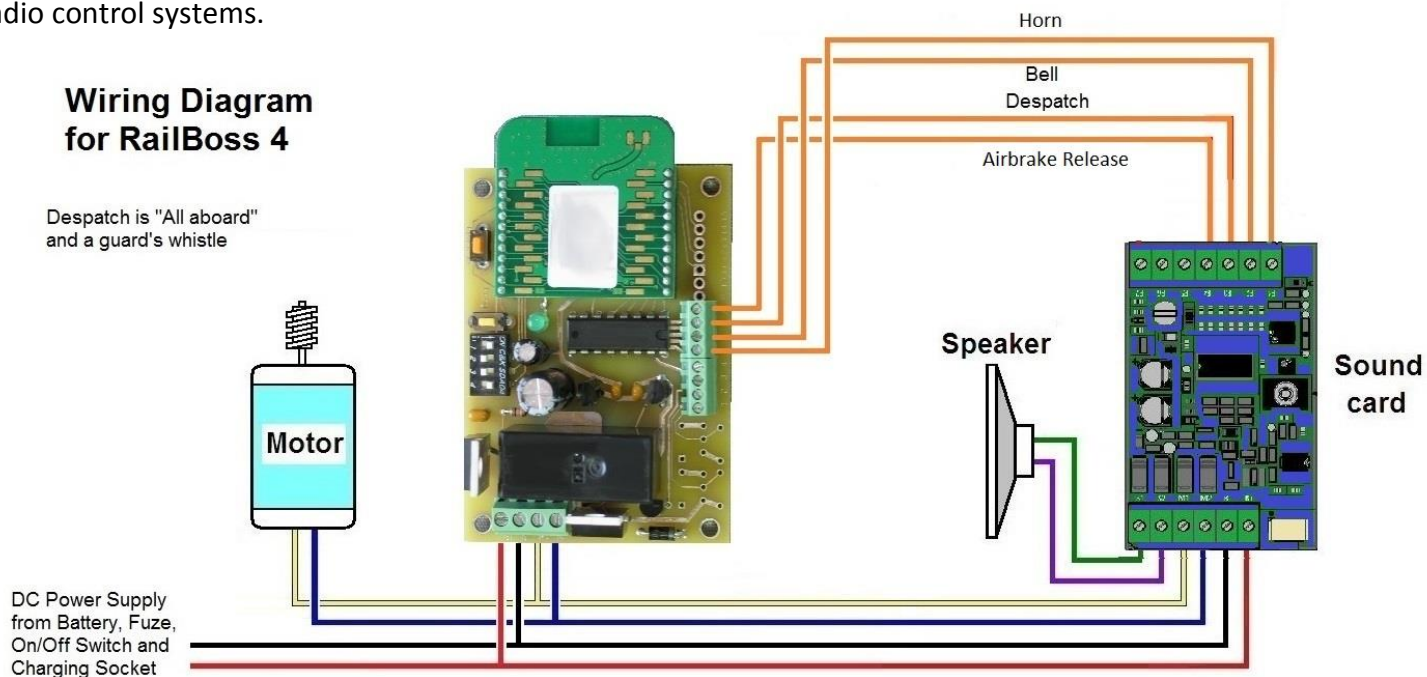

The RailBoss 4 can trigger four sound functions. The fifth and sixth soundcard triggers, the turbocharger and engine start/stop, therefore cannot be radio controlled and will need to be switched on, if required, by the IR remote control or be set to sound automatically.

The above wiring diagrams can be seen in colour by visiting the web site at www.mylocosound.com/installs. Also shown are specific wiring diagrams for RCS, Barker, Mac 5, RailBoss, Mtronics, Roundhouse, Electronise and LocoLinc.

The Crest Revolution can trigger all sound functions and is connected as shown in the diagram below. To connect the Crest Revolution, the adaptor plug for custom installations is used with the outer red, orange, grey and black wires being connected as shown. All auxiliary functions should be set to momentary by selecting MENU – ASSIGN FUNCTIONS – AUX FUNC SETUP. However, the bell, if in use, can be set to latch.

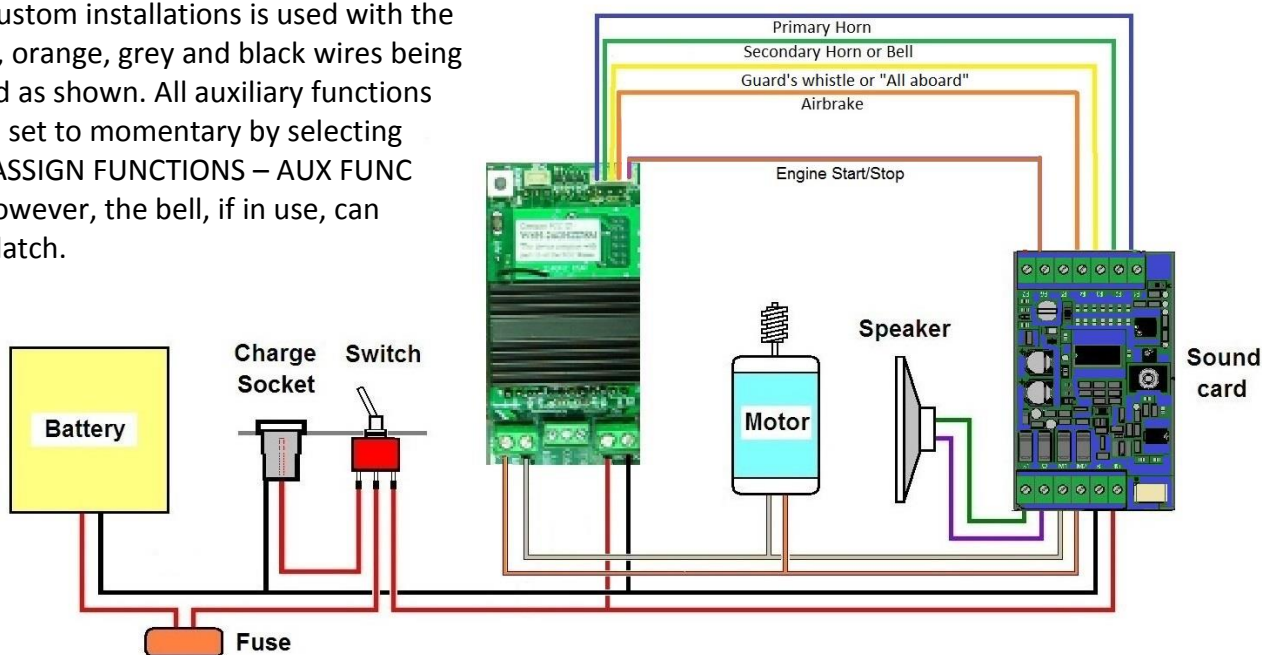

Note also that early Revolution receivers, without the onboard sound, will start the soundcard immediately when power is switched on. However this will not happen with later Revolution receivers with the onboard sound. With the later ones you will need to throttle up three button presses to switch on the sound which will then stay on.

6. THE INFRA-RED RECEIVERS

The infra-red receivers accept commands from the handheld remote control to adjust or trigger sounds. Two receivers are provided. One is fixed in the middle of the soundcard. The other is on a flying lead which plugs into the small white socket as shown on page one.

In some installations, the soundcard is visible when installed in the loco. This usually occurs when the soundcard is mounted on the floor of a cab, with or without windows. In this case, the remote control can be pointed directly at the soundcard and the on-board receiver is all that is needed.

If the soundcard is within the loco and is not visible then the flying lead needs to be used. Plug it into the white socket and glue the black receiver, round side outwards, to any external surface of the loco to which you can easily point the radio control. Do not paint the receiver. When the soundcard is on the floor of the vehicle then a common practice is to drill a hole in the floor and glue the black receiver to the underside. You can then operate the TV remote by pointing it under the vehicle so that the IR signal bounces up off the sleepers and ballast.



7. CONFIGURING THE SOUND CARD

The soundcard has two modes:

1. Setting mode in which you can select the sounds you want and can make adjustments to them.
2. Run mode in which the soundcard does its job on your railway.

All settings are done using the remote control and we will cover that first. So place the soundcard into Setting mode by pointing the remote control at the soundcard or the receiver on the end of the flying lead and press the **Mute** button. The LED on the soundcard will blink slowly and all sounds will cease.

Next press one of the keys on the remote control to change the sounds listed below. When you press a button, the LED will start blinking faster. At any time, you can press the **Mute** button and then the button you are changing to hear the sound you have selected and then press **Mute** again to turn it off. The options are:

Power Button – Battery or Track Power. The soundcard can be used with battery powered, radio controlled locomotives or with locomotives which are powered from the track (but not DCC). Press this button to change from one to the other:

- 1 beep – Battery powered radio control.
- 2 beeps – Track power with a 9 volt rechargeable battery to maintain sound at low track voltage. In this case, the soundcard will automatically turn itself off when the locomotive has not moved for sixty seconds. Turning the track power up a little will turn the soundcard back on. The soundcard will automatically recharge the battery when the track voltage exceeds 10v.
- 3 beeps – Track power with a 7.2 volt rechargeable battery. As above except that the battery will recharge when the track voltage exceeds 8.2v and therefore at a lower speed.

Button 0 – Reserved for future use.

Button 1 – Horn 1. This is used to select the style of horn which suits your locomotive. Each of these horns has an adjustable volume. Each time you press the 1 button the number of beeps will change to indicate that the horn has been switched between the five available which are:

- 1 beep – Baguley Drewry horn
- 2 beeps – Whitcomb horn **(Default)**
- 3 beeps – Klaxon
- 4 beeps – GE Air Horn
- 5 beeps – GE Electric Horn
- 6 beeps – European Two Tone

If you wish to hear that horn, press the Mute button on the remote control and then button 1 to start the horn and then again to stop it. While the horn is sounding, you can use the channel and volume buttons to change the pitch and volume respectively. However the klaxon horn pitch is fixed.

Button 2 – Bell. This is used to select the type of bell from the list below.

- 1 beep – Manual bell. Starts ringing repeatedly when the button is pressed until the button is pressed again.
- 2 beeps – Timed bell. When F2 is triggered, rings repeatedly for a predetermined time. To set that time, press the Mute button to exit setting mode and then press Button 2 to ring the bell. When the bell has rung for as long as you want, press Button 2 again to stop the ringing. The time is then set and the bell will ring for that time when F2 is triggered while running.
- 3 beeps – Automatic bell. Rings when the motor voltage is less than 4 volts.
- 4 beeps – Automatic bell. Rings when the motor voltage is less than 8 volts.
- 5 beeps – Automatic bell. Rings when the motor voltage is less than 12 volts.
- 6 beeps – Manual bell. Rings once only each time the button is pressed.
- 7 beeps – Bell not required. Button sounds a short whistle toot. **(Default)**

Button 3 – Guard. This is used to select the guard's sounds from the list below.

- 1 beep – Sounds a guard's Acme Thunderer whistle.
- 2 beeps – Sounds "All aboard".
- 3 beeps – Sounds "All aboard" and then the guard's whistle. **(Default)**

Button 4 – Brakes. This gives you three braking options:

- 1 beep – No braking sounds required. **(Default)**
- 2 beeps – Automatic brake squeal whenever the locomotive comes to a halt.
- 3 beeps – Automatic airbrake release when moving off.
- 4 beeps – Automatic brake squeal whenever the locomotive comes to a halt plus automatic airbrake release when moving off.

Button 5 – Not used

Button 6 – Engine starting and stopping

1 beep – Manual. The engine will start automatically at power up. Pressing the button 6 will then shut down and start up the engine using the starter motor **(Default)**

2 beeps – Automatic. The engine will shut down after one minute of no movement and will start up again, using the starter motor, when the throttle is given a slight nudge.

3 beeps – Manual. At power up the engine will not start automatically but an airbrake release will be heard to confirm that the soundcard is working. Pressing the button 6 will then start up and shut down the engine using the starter motor.

Button 7 – Throttle Type. This will operate in three ways:

1 beep – Manual notch up. Revs increase proportionally to the speed. **(Default)**

2 beeps – Automatically revs up to notch 5 to move off with engine revs twice tickover.

3 beeps – Automatically revs up to notch 8 to move off with revs three times tickover.

4 beeps – Revs increase proportionally to the speed with short gear changes.

5 beeps – Revs increase proportionally to the speed with long gear changes.

It is important to tell the soundcard when your loco starts moving. Do this by slowly increasing the throttle until the loco is just about to start to move. Then press the power button on the remote control. This tells the soundcard the voltage at move off.

When the loco is static, the channel up/down buttons change the tickover rate. When the loco is running, the channel up/down buttons change the running rev rate.

Button 8 – Engine Type. There are two types of engine to choose between:

1 beep – Perkins industrial diesel. **(Default)**

2 beeps – Ruston & Hornsby four cylinder industrial diesel

3 beeps – Baguley Drewry diesel

4 beeps – Petrol and Gas Mechanical for Small Simplex, “Tin Turtle”, Davenport, etc.

5 beeps – Large Simplex

6 beeps – Whitcomb narrow gauge switcher

7 beeps – GE 25 tonner

Button 9 – The Operating Mode. There are two operating modes available:

1 beep – Indicates manual mode. In this mode all sounds are triggered according to the above settings. The whistle will sound for as long as its button is pressed. **(Default)**

2 beeps – Indicate simple automatic mode. This is designed for controllers which have no function buttons, as is often the case with track power, or at exhibitions, etc. where you don't want to operate manually. The whistle will sound once automatically when the loco moves off and then once more three times a minute when the loco is in motion. A reed switch can be placed under the loco and be connected to the F1 terminal to make the whistle sound when the loco passes over a magnet. Another reed switch, connected to the F2 terminal, can be used to trigger the second horn which will turn on when crossing a magnet and then off at the next magnet.

3 beeps – Indicate trigger mode. Again this is designed for controllers which have no function buttons but this mode has no automatic horns. A reed switch can be placed under the loco and be connected to the F1 terminal to make the horn sound when the loco passes over a magnet.

You can change these settings whenever you wish and those changes will be effective immediately.

Holding down the 0 button until you hear five beeps will cause the soundcard to reset itself back to its factory defaults.

Channel Up/Down – Motion Sensitivity. When the loco is in motion, the soundcard changes the sounds according to whether the loco is accelerating, coasting or slowing down. If you find that the sounds are changing too frequently then press Mute and then the Channel Up button. You will hear one to five beeps. The higher the number of beeps, the less sensitive the soundcard is to changes of motion. Use the Channel Down button to reduce the number of beeps and make it more sensitive to changes in motion.

11. SETTING THE ENGINE REVS

This is a once only exercise although you can repeat it later if you want to make a change.

First press Mute to stop the sound and go into programming mode. Then use buttons 5, 6, 7 and 8 to set your chosen engine as described in the previous section.

The last step then is to set the rev rates when static and when in motion. Press Mute to come out of programming mode so that you can hear the sounds. Then do the following:

1. Use the channel up/down buttons to adjust the tickover revs to the desired rate.
2. Turn up the locomotive throttle until you get to the point where you want the revs to increase. Then press the Power button on the remote control. Most people press the Power button at a very small amount of throttle movement so that the engine revs increase well before the locomotive starts moving.
3. If the engine type (Button 7 above) is set to 3 or 4 beeps then you need to do no more. The locomotive is ready to run.
4. If the engine type (Button 7 above) is set to anything else then the revs will increase as the locomotive speed increases. With the engine in motion, you can increase or decrease the rate at which the revs change by using the channel up/down buttons.

12. OPERATING THE SOUND CARD

When the loco is running, the engine sounds should operate automatically, getting louder when accelerating and softer when slowing down or idle.

Where your controller has function buttons then you can use them as follows to trigger terminals F1-F7:

- Function F1. Sounds the main horn.
- Function F2. Sounds the bell or short horn.
- Function F3. Sounds “All aboard” and/ or the guard’s whistle.
- Function F4. Sounds the airbrake release.
- Function F6. Starts and stops the engine.
- Function F7. Changes gear.

13. TROUBLE SHOOTING GUIDE

THE REMOTE CONTROL WON'T WORK

Start the soundcard, press any button on the remote control and the LED should flash. If it does not flash then the battery probably needs replacing. If the battery is okay then try stretching the battery contact springs and then replace the battery.

If the LED flashes but the soundcard does not respond then the Sony™ coding may have been lost and can be reset as follows.

Refer to the remote control's instructions for resetting the Sony coding. You will probably find a number of codes listed for Sony and will need to try each one until you get to the code which operates the soundcard volume, mute and function buttons correctly. For the Brightstar, hold down the Setup button until the LED comes on and then enter 605. The LED will go off and it is ready for use.

If the remote control still does nothing then the problem may be the infra-red receiver on the loco which must not be painted or obstructed.

I GET NO SOUND AT LOW SPEEDS WHEN USING TRACKPOWER

On trackpower, you may get no sound at low speeds until the track voltage gets up to about nine volts. This indicates that the support battery is flat. Charge the battery by running the loco at half speed for ten minutes.

I GET NO SOUND AT ALL

Press the Mute button on the remote control in case the sound has been accidentally turned off.

Switch the loco off and then on again. When the soundcard starts, the LED should flash once. If not then use a multimeter to check that there is at least nine volts at the B+ and B- terminals and the M1/M2 voltage is greater than zero to wake up the soundcard. If not then check your wiring in case something has come adrift.

Check that the speaker is connected correctly.

If you are bench testing and there is a light shining on circuit board then this can put the soundcard into factory programming mode and stop the sound. In that case, the yellow LED next to the F1 terminal will stay on. You can fix this by covering the IR receiver on the soundcard and on the flying lead, if fitted.

THE SOUND CARD MAKES A CLICKING NOISE OR SHUTS DOWN

This most often occurs when the horn is sounded. It is caused by the soundcard restarting because there is insufficient voltage in the track or the battery to sustain the volume setting. Recharge the battery.

WHEN INSTALLED IN A LOCO, THE SOUND STOPS INTERMITTENTLY AND I HAVE TO RESET THE CONTROLLER TO GET IT GOING AGAIN

The soundcard maximum output is 1.5 amps. If this is exceeded as a result of a short circuit, a heavy load and/or high volume settings then the soundcard will shut down. Also, if the soundcard is installed in a very confined space and is run for a prolonged period at high power then it can overheat and switch itself off while it cools down.

HOW TO RESET YOUR SOUND CARD

A time may come when you have been adjusting the sound and you want to start again. This can be achieved by resetting the soundcard back to the settings when it left the factory. You can do this by pressing the 0 button on the remote control and hold it down until the soundcard will beep five times. The reset is then complete.

14. USING AN EXTERNAL AMPLIFIER FOR RIDE ON RAILWAY LOCOMOTIVES

When used in 5 inch and 7¼ inch ride on railways there is a lot of environmental noise. The output of the soundcard alone is not sufficient for these environments and an external amplifier needs to be used. The wiring diagram overleaf shows how the soundcard can be interfaced to a commercial stereo amplifier in a loco with 24v motors powered by two 12 V batteries.

Note that the soundcard can handle a maximum of 24 volts DC. A battery which is labelled as 24 volts will typically output 28 volts when fully charged and will therefore damage the soundcard if connected directly. The two 10K resistors on the M1/M2 terminals keep the voltage down to 24v.

A 2x15 watt stereo amplifier is suitable. Other amplifiers may require the 100Ω resistor to be changed. If the output volume is too low then raise the value of the 100Ω resistor.

A single speaker can be used on the right output or two speakers on the left and right outputs.

Any of the five functions can be used by means of a pushbutton between the function terminal and ground. The sound functions available are horn, bell, guard's whistle, airbrake release and engine start/stop. Only the horn wiring is shown in the diagram..

The installation can be made more robust by enclosing the soundcard, capacitor and two resistors into a plastic project box as shown in the diagram. The whole can then be fixed to the top of the amplifier using silicon.

Select a speaker which matches the impedance and power output of the amplifier. It is also important to make a soundbox which is an airtight fit to the back of the speaker. This will improve both volume and sound quality.

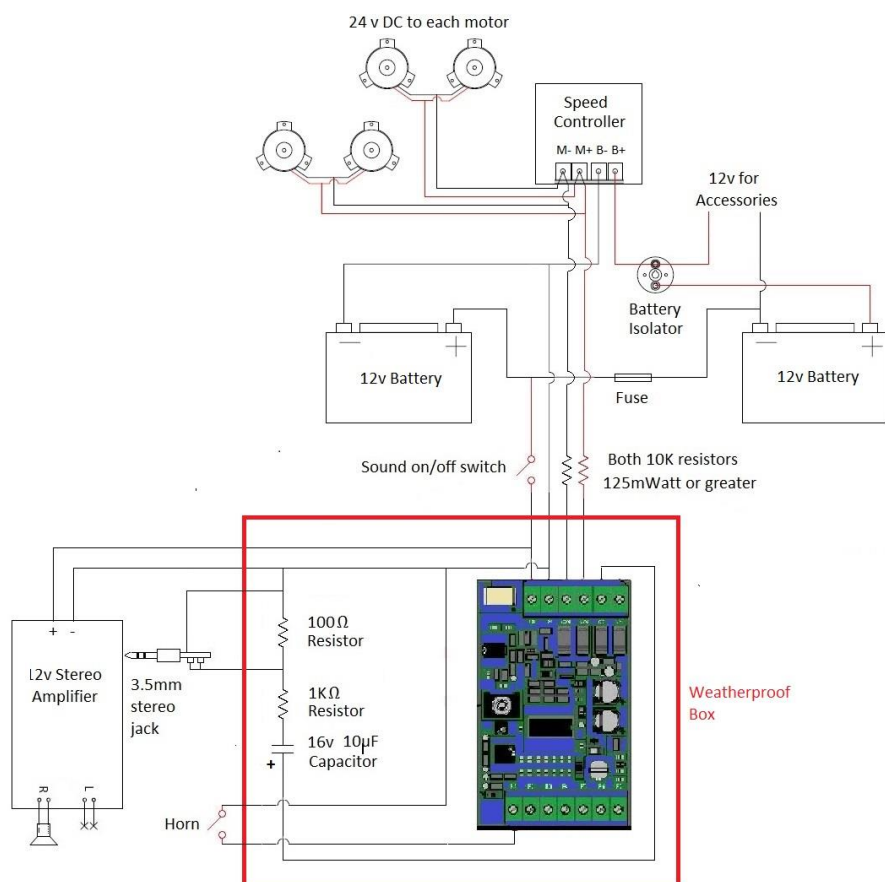

PLC009 Light Diesel Instructions US.doc 28 May 2022 Version 20E

For more information, please visit the web site at www.mylocosound.com or e-mail sales@mylocosound.com.

Copyright © 2013-22 MyLocoSound Pty. Ltd.

Remote Control	Radio Control		
Power		Set Start Voltage for Rev Up	
VOL up/down		Change Volume of active sound	
CH up/down		Change Sound	Engine tickover rate when static
			Engine rev rate when moving
Mute		Sound on/off	
Button 1	F1	Horn Type	
		1 beep	Baguley Drewery
		2 beeps	Whitcomb
		3 beeps	Klaxon
		4 beeps	GE Air Horn
		5 beeps	GE Electric Horn
		6 beeps	European Two Tone
Button 2	F2	Bell Modes and Short Horn	
		1 to 6 beeps	Bell Modes
		7 beeps	Short Horn
Button 3	F3	Guard/Conductor	
		1 beep	Guard's Whistle
		2 beeps	All Aboard
		3 beeps	All Aboard and Guard's Whistle
Button 4	F4	Brake release and/or squeal	
		1 beep	No Brake sounds
		2 beeps	Brake Squeal
		3 beeps	Airbrake Release
		4 beeps	Brake Squeal and Airbrake Release
Button 6	F6	Engine start/stop	
Button 7		Throttle Type	
		1 beep	Engine revs up steadily with throttle
		2 beeps	Revs up to notch 5
		3 beeps	Revs up to notch 8
		4 beeps	Short mechanical gear changes
		5 beeps	Long mechanical gear changes
Button 8		Engine Type	
		1 beep	Perkins Industrial diesel
		2 beeps	Ruston & Hornsby diesel
		3 beeps	Baguley Drewery diesel
		4 beeps	Petrol and Gas mechanical
		5 beeps	Large Simplex
		6 beeps	Whitcomb diesel
		7 beeps	GE 25 tonner
Button 9		Control Mode	
		1 beep	Manual
		2 beeps	Auto horn every 20 secs
		3 beeps	Triggered horn
Power		Power Mode	
		1 beep	Battery radio control
		2 beeps	Track power with 9v battery
		3 beeps	Track power with 7.2v battery
Button 0 Held For > 5 seconds		Reset above settings to defaults	

