

# MYLOCOSOUND

## UNIVERSAL SOUND FOR LARGE SCALE, DIESEL LOCOS & RAILCARS

### 1. OVERVIEW

- Easy installation using screw terminals with no soldering.
- Uses a TV remote control to adjust the sounds to match the prototype loco.
- Provides six selectable engine sounds which adjust to match the loco speed and load.
- Selectable engine start up
- Six single and dual tone horns with adjustable pitch to suit the loco.
- Full remote control of the horn, bell, airbrake, guard's whistle and optional turbocharger.
- Optional brake squeal.
- For track powered DC or DCC or battery powered radio controlled railways.
- Measures 55mm x 33mm x 11mm.

### 2. CONTENTS

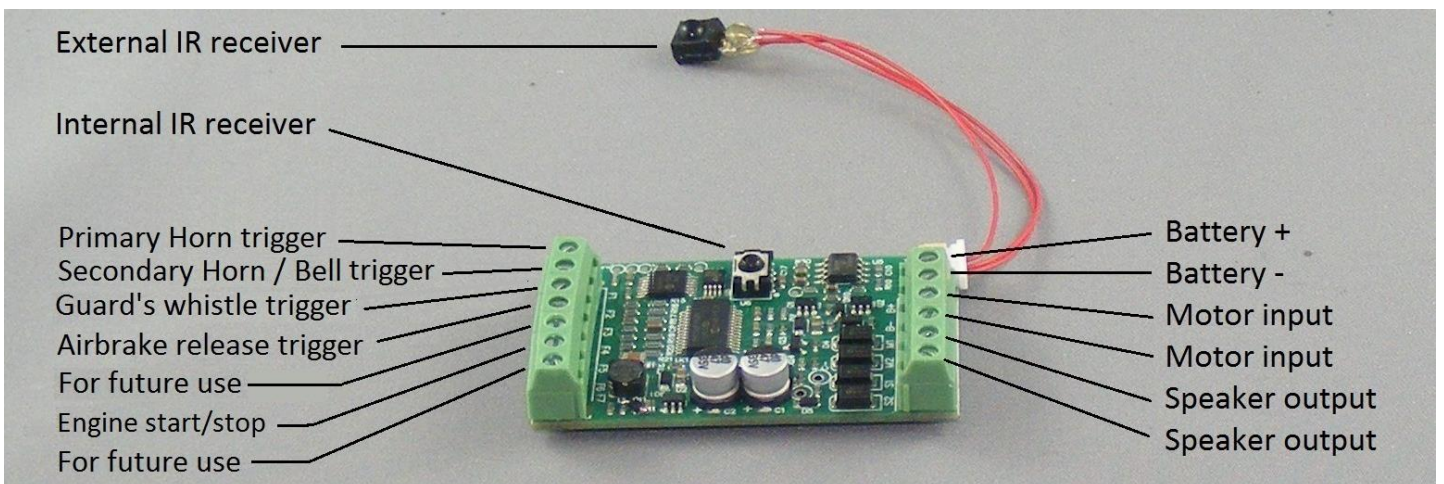

The soundcard generates synthesised sound which is adjustable to reproduce the sounds of most diesel locos and railcars. The terminal connections on the right are necessary for the soundcard to generate diesel sounds which vary with the loco speed and load. The terminal connections on the left trigger the various sounds where the locomotive controller has the appropriate outputs available.

Sounds can also be triggered by a Sony infra-red TV remote control which can be purchased locally. Low cost, universal, TV remote controls are available from most consumer electronics stores and need to be set to Sony coding to work with the soundcard. Although it can be used when running in the garden, the remote control is intended mainly for the adjustment and testing of sounds.

The remote control communicates with the soundcard via two infra-red receivers. One is located on the soundcard and the other is on a flying lead which allows it to be fixed to any external surface of the loco. Adjustments to the sounds can then be made without taking the loco apart to access the soundcard.



### 3. SPEAKERS AND SOUND QUALITY

The soundcard requires an 8 ohm loudspeaker which is not included. A 4 ohm speaker can also be used but you may cause the soundcard to overheat and temporarily shut down if the volume is very high and the soundcard is in a confined space. Your choice of speaker is highly important because it determines the quality of the sound produced.



1. To get maximum volume, the rated (or RMS) power should be 2 watts. A 1 watt or lower speaker will fall short on volume. Speakers exceeding 2 watts can be used but will not produce any more volume due to the limited output of the soundcard amplifier.
2. The resonant frequency should ideally be below 350 Hz but certainly below 500 Hz. The lower the resonant frequency, the deeper the diesel engine, horn, etc.
3. Use the largest diameter which you can fit in your loco. Two inches is the most popular.



For a better quality sound and more volume, the speaker needs to be baffled. That means that it needs to be built into the front face of an airtight box so that sound is heard only from the front of the speaker and none from the back. The plastic top of a spray paint can is good for making a baffle as shown in the diagram.

A good solution, which ensures high quality sound with lots of deep throbbing bass, is to purchase an 8 ohm impedance external speaker unit for iPod and MP3 music players and remove the two speaker modules, in their enclosures, for use in two locos. These are readily available at consumer electronics stores.



Speakers can be connected to the terminals either way around.

## Important Notes

The soundcard is designed for outdoor use and may not work correctly under bright incandescent lights on a workbench. LED lights are okay.

The soundcard is in a “sleep” mode when not in use. Connecting it to power at the B+ and B- terminals will not wake it up. It must also be connected to a motor at the M1 and M2 terminals as well. The small voltage it sees at the motor will wake it up and it will then stay awake for as long as it has power.

#### 4. INSTALLING THE SOUND CARD IN A TRACK POWERED LOCOMOTIVE, DC OR DCC

The soundcard is suitable for use on analogue DC track powered railways on which the following wiring diagram should be used:

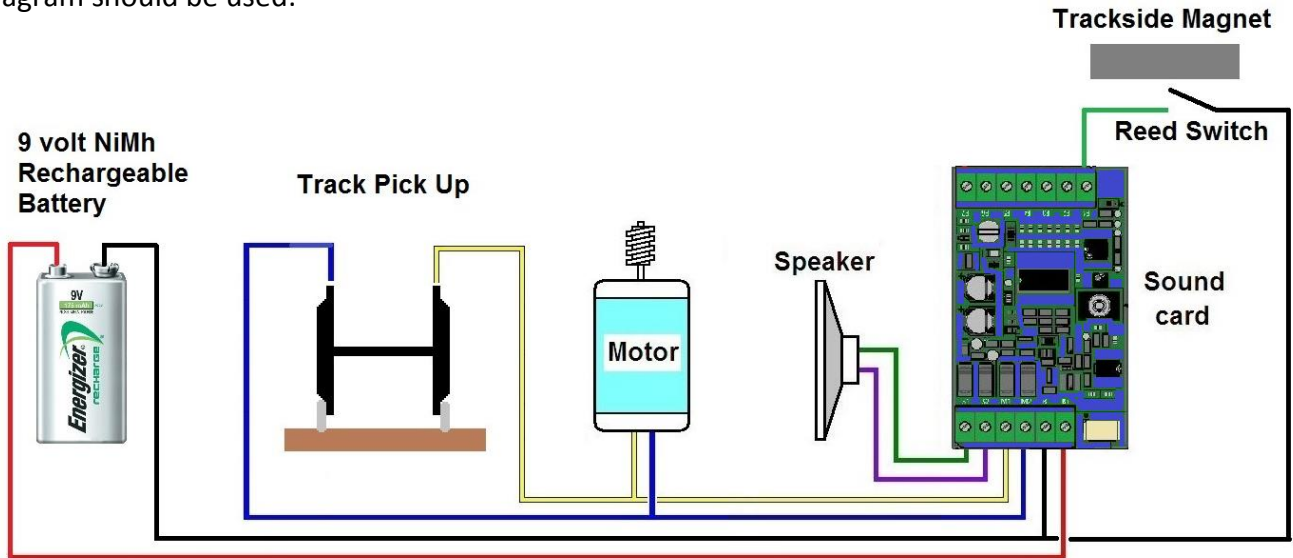

The wiring diagram below shows the connections for the DC jumper board in a Bachmann locomotive.

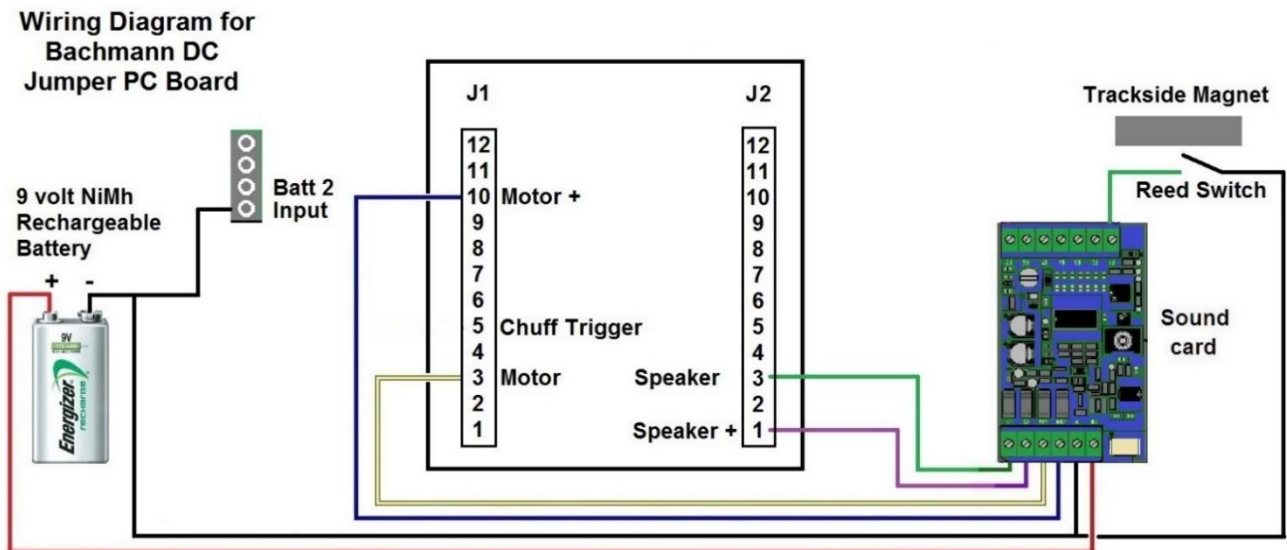

On DCC track powered railways in locomotives using a basic decoder, the wiring is a little different:

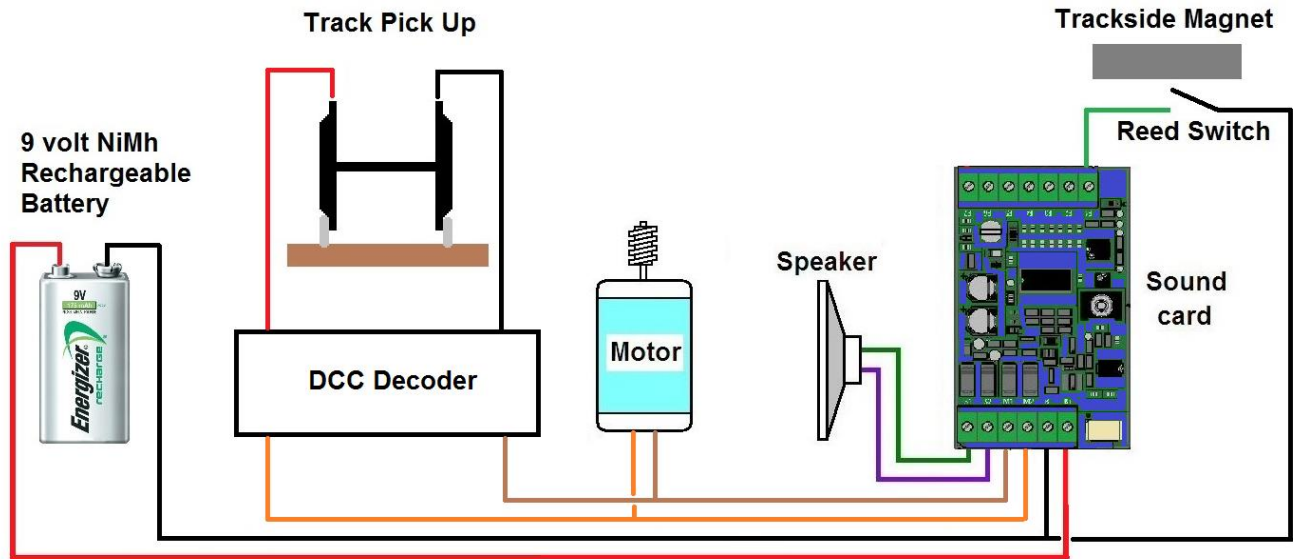

When the motor voltage is below nine volts it is insufficient to power the soundcard. Therefore a nine volt PP3 battery is used to drive the soundcard and produce sound when the loco is static or moving slowly. This battery will be automatically recharged whenever the motor voltage is at least one volt higher than the battery voltage so there should never be a need to remove the battery for recharging. However, the battery must be a Nickel Metal Hydride type; Lithium and Nickel Cadmium batteries must not be used. On small shunting layouts, the loco speed is often not high enough for charging to take place. Some owners of shunting layouts put an isolation switch on the loco motor circuit so that they can turn up the power to recharge the battery without having the loco moving.

On analogue DC layouts which have pure DC controllers (as opposed to PWM controllers) you may need to give the throttle a bit of a tweak to start the sound. On those layouts, the sound will automatically turn off after one minute of inactivity and another tweak will turn it back on. With the more common PWM controllers and with DCC the sound will turn on automatically and stay on.

When the loco is removed from the track the soundcard will go into a “sleep” mode to preserve the battery charge. A fully charged PP3 battery should retain charge for over a year.

Because most DC controllers do not have function buttons, an alternative way of triggering the horn, bell and other sounds needs to be found. The options are:

1. You can set the horn to sound automatically three times a minute when the train is running. Other sounds can also be triggered automatically. This is described in section 6.
2. You can connect the soundcard horn trigger to a reed switch which you mount on the bottom of the loco. Then install magnets in the track where you want the horn to sound eg. at the approaches to a level crossing. The horn will then sound briefly as the loco crosses each magnet.
3. Use the remote control, supplied with the soundcard, to trigger all the sounds as described in section 6. However, infra-red remote controls are not designed for long distance use outside. On an overcast but bright day, the remote control, powered by AA or AAA batteries will probably operate up to three metres away.



Any combination, or all, of these methods can be used.

With DCC, the soundcard is not a decoder and cannot trigger sounds directly from the controller. Therefore the above methods are used to trigger the sounds. Some decoders have a servo output which can be used to trigger sounds from the controller buttons by using a servo switch. They may also have a constant DC power output which can replace the battery if it is in the voltage range 8 to 24 volts. These connection options are shown below:

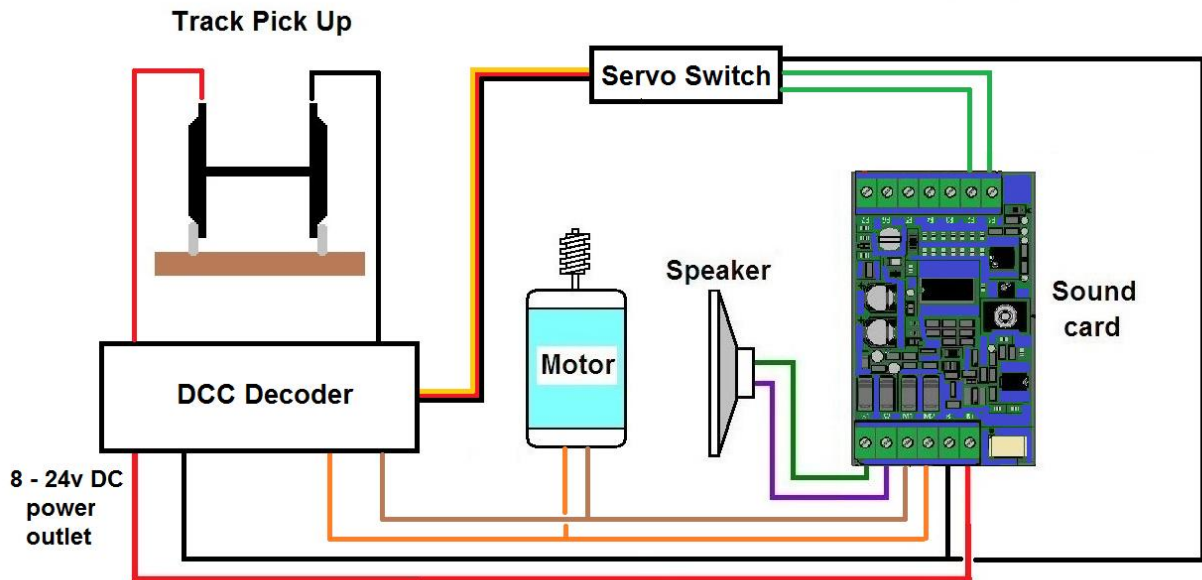

Many decoders also have function outputs which can be used to trigger sounds. However, this is technically difficult and you should only attempt it if you are very familiar with your decoder and the setting of CVs.

Now continue reading at section 6.

## 5. INSTALLING THE SOUNDCARD IN A BATTERY POWERED LOCOMOTIVE OR RAILCAR

The wiring diagram below shows a typical installation for common types of battery powered radio control systems.

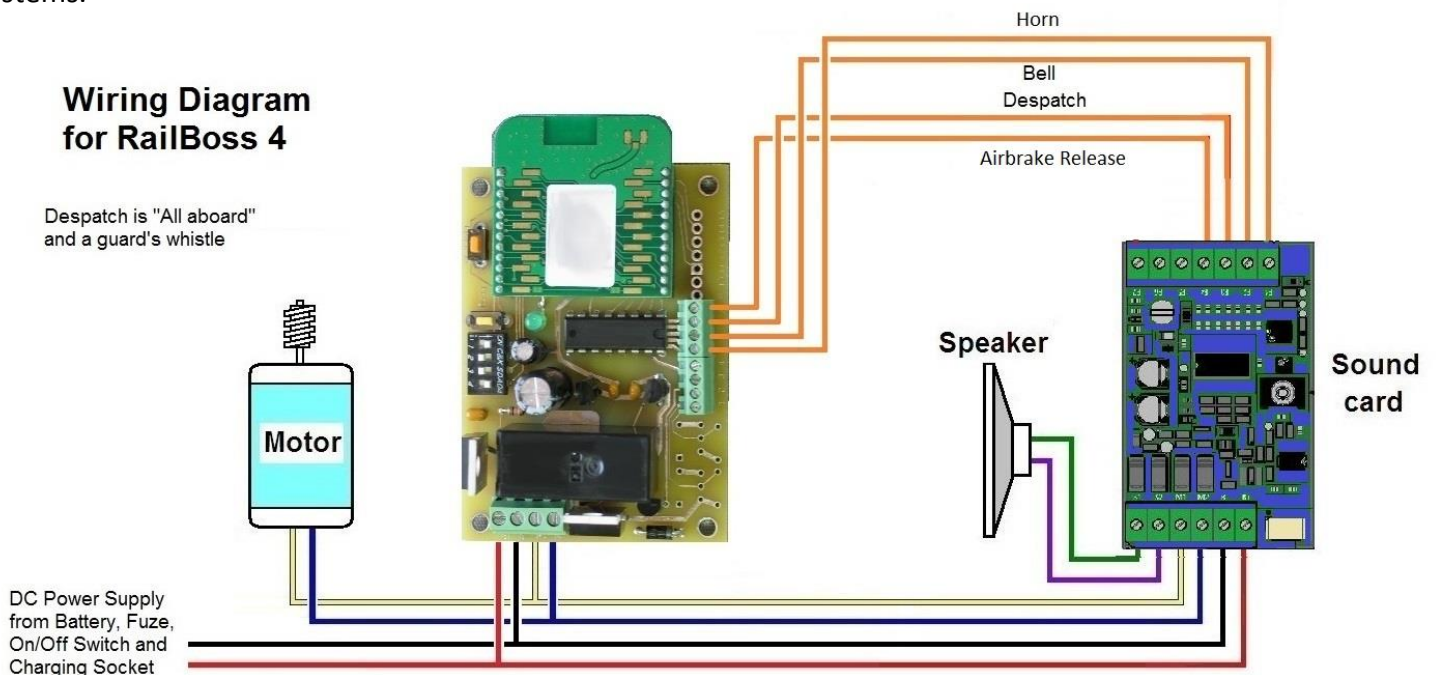

The RailBoss 4 can trigger four sound functions. The fifth and sixth soundcard triggers, the turbocharger and engine start/stop, therefore cannot be radio controlled and will need to be switched on, if required, by the IR remote control or be set to sound automatically.

The above wiring diagrams can be seen in colour by visiting the web site at [www.mylocosound.com/installs](http://www.mylocosound.com/installs). Also shown are specific wiring diagrams for RCS, Spoerer, Mtronics, Roundhouse and LocoLinc.

The Crest Revolution can trigger all six sound functions and is connected as shown in the diagram below.

To connect the Crest Revolution, the adaptor plug for custom installations is used with the outer red, orange, grey and black wires being connected as shown. All auxiliary functions should be set to momentary by selecting MENU – ASSIGN FUNCTIONS – AUX FUNC SETUP. However, the bell, if in use, can be set to latch.

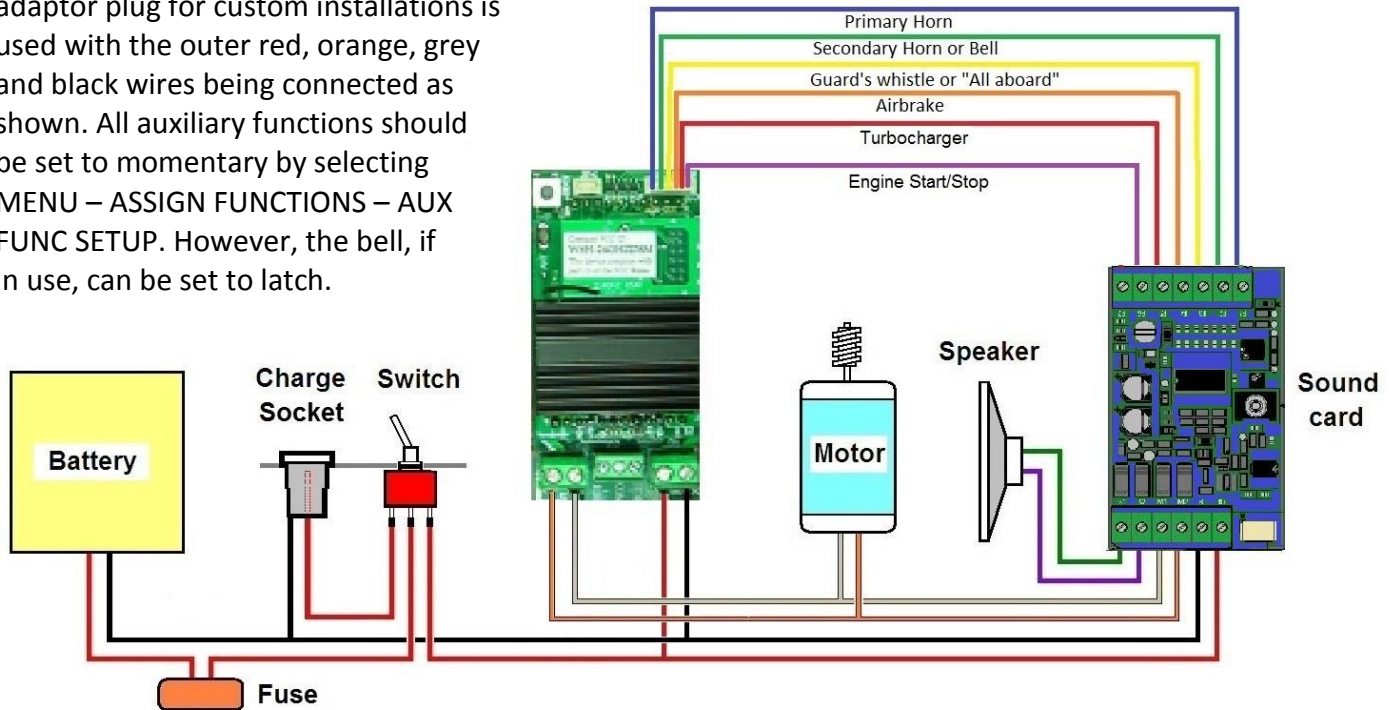

Note also that early Revolution receivers, without the onboard sound, will start the soundcard immediately that power is switched on. However this will not happen with later Revolution receivers with the onboard sound. With the later ones you will need to throttle up three button presses to switch on the sound which will then stay on.

## 6. THE INFRA-RED RECEIVERS

The infra-red receivers accept commands from the handheld remote control to adjust or trigger sounds. Two receivers are provided. One is fixed in the middle of the soundcard. The other is on a flying lead which plugs into the small white socket as shown on page one.

In some installations, the soundcard is visible when installed in the loco. This usually occurs when the soundcard is mounted on the floor of a cab, with or without windows. In this case, the remote control can be pointed directly at the soundcard and the on-board receiver is all that is needed.

If the soundcard is within the loco and is not visible then the flying lead needs to be used. Plug it into the white socket and glue the black receiver, round side outwards, to any external surface of the loco to which you can easily point the radio control. Do not paint the receiver.

## 7. THE REMOTE CONTROL

The soundcard will operate with any Sony™ TV remote control using the buttons described in this section. It will also operate with any universal remote control when it is set to Sony coding. You will probably find a number of codes listed for Sony and will need to try each one until you get to the code which operates the soundcard volume, mute and function buttons correctly.

Please ensure that your remote control has batteries installed and follow the instructions which come with it to set the coding. For the Brightstar, hold down the Setup button until the LED comes on and then enter 605. The LED will go off and it is ready for use.

Note that the buttons on the remote control auto-repeat if held down. If you want a single event to occur, like turning on the safety valve, then press the safety valve and release it immediately. If you want to make a large change in volume or tone then you can hold the button down to avoid the need to press the button repeatedly.

The Mute button will start and stop the sound.



## 8. CONFIGURING THE SOUND CARD

The soundcard has two modes:

1. Setting mode in which you can select the sounds you want and can make adjustments to them.
2. Run mode in which the soundcard does its job on your railway.

All settings are done using the remote control and we will cover that first. So place the soundcard into Setting mode by pointing the remote control at the soundcard or the receiver on the end of the flying lead and press the **Mute** button. The LED on the soundcard will blink slowly and all sounds will cease.

Next press one of the keys on the remote control to change the sounds listed below. When you press a button, the LED will start blinking faster. At any time, you can press the **Mute** button and then the button you are changing to hear the sound you have selected and then press **Mute** again to turn it off. The options are:

**Power Button – Battery or Track Power.** The soundcard can be used with battery powered, radio controlled locomotives or with locomotives which are powered from the track (but not DCC). Press this button to change from one to the other:

1 beep – Battery powered radio control.

2 beeps – Track power. In this case, the soundcard will automatically turn itself off when the locomotive has not moved for thirty seconds. Turning the track power up a little will turn the soundcard back on.

**Button 0 – Country.** This is used to select the part of the world which your locomotive comes from. Your choice here will determine the selection of horns offered and how those horns are sounded. When you press the 0 button, one or more beeps will be heard to indicate the country currently selected as follows:

1 beep – Britain

2 beeps – North America

3 beeps – Australasia

Press the 0 button repeatedly to select the region you want. The sole purpose of changing the country is to select default horns and sounds which are appropriate. If you want to use a horn from another country because it fits your particular locomotive then there is no problem with changing the country to access that horn.

**Button 1 – Horn.** This is used to select the style of horn which suits your locomotive. Every one of these horns has an adjustable pitch and volume. Each time you press the 1 button the number of beeps will increase to indicate that the horn listed below has been selected. If you wish to hear that horn, press the Mute button on the remote control and then button 1 to start the horn and then again to stop it. While the horn is sounding, you can use the channel up/down buttons to vary the pitch and also the volume buttons. The pre-selected horns available are:

<b>Beeps</b>	<b>Horn</b>	
1	European	<b>(British default)</b>
2	Nathan Single Chime	(also used in the UK).
3	Nathan Five Chime	<b>(US default)</b>
4	Leslie Five Chime	
5	WABCO Two Chime	
6	Australian	<b>(Australasian default)</b>

Note that all of these are single tones when button 2 is set to 1 to 6 beeps to ring the bell.

They are all two tone when button 2 is set to 7 or 8 beeps.

The pitch of horns 1 to 5 can be adjusted by using the channel up/down buttons. Horn 6 has a fixed pitch.



**Button 2 – Bell.** This is used to select the type of bell from the list below.

1 beep – Manual bell. Starts ringing repeatedly when the button is pressed until the button is pressed again.

2 beeps – Timed bell. When F2 is triggered, rings repeatedly for a predetermined time. To set that time, press the Mute button to exit setting mode and then press Button 2 to ring the bell. When the bell has rung for as long as you want, press Button 2 again to stop the ringing. The time is then set and the bell will ring for that time when F2 is triggered while running.

3 beeps – Automatic bell. Rings repeatedly when the motor voltage is under 4 volts. **(US Default)**

4 beeps – Automatic bell. Rings repeatedly when the motor voltage is less than 8 volts.

5 beeps – Automatic bell. Rings repeatedly when the motor voltage is less than 12 volts.

6 beeps – Manual bell. Rings once only each time the button is pressed. **(Australasian Default)**

7 beeps – Bell not required. Buttons 1 and 2 and functions F1 and F2 sound a two tone horn. Button/function 1 sounds Dee-Dar and button/function 2 sounds Dar-Dee. **(British Default)**

8 beeps – Bell not required. Buttons 1 and 2 and functions F1 and F2 sound a two tone horn. Button/function 1 sounds Dee only and button/function 2 sounds Dar only. Therefore by use of the two buttons/functions you can play different sequences and tunes.

When two tone horns are in use, the channel up/down buttons will change the pitch of whichever tone is playing at the time.

**Button 3 – Guard.** This is used to select the guard's sounds from the list below.

1 beep – Sounds a guard's Acme Thunderer whistle. **(British Default)**

2 beeps – Sounds "All aboard". **(US Default)**

3 beeps – Sounds "All aboard" and then the guard's whistle. **(Australasian Default)**

**Button 4 – Brakes.** This gives you three braking options:

1 beep – No braking sounds required. **(Default)**

2 beeps – Automatic brake squeal whenever the locomotive comes to a halt.

3 beeps – Automatic airbrake release when moving off.

4 beeps – Automatic brake squeal whenever the locomotive comes to a halt plus automatic airbrake release when moving off.

**Button 5 – Turbocharger and Exhaust.** These can be switched on or off by:

- 1 beep – Turbocharger and exhaust reverberation not required. **(Default)**
- 2 beeps – Turbocharger sounds automatically according to the locomotive motion. When the turbocharger is selected, the channel up/down buttons can be used to change the pitch. Therefore the turbocharger has to be temporarily turned off if you wish to change the engine rev rate using these buttons.
- 3 beeps – Exhaust reverberation when accelerating.

**Button 6 – Engine starting and stopping**

- 1 beep – Manual. Pressing the button 7 will shut down and start up the engine using the starter motor **(Default)**
- 2 beeps – Automatic. The engine will shut down after one minute of no movement and will start up again, using the starter motor, when the throttle is given a slight nudge.

**Button 7 – Engine Type.** This will operate in three ways:

- 1 beep – Manual notch up with no gear change. Revs increase proportionally to the speed.
- 2 beeps – Mechanical transmission with gear changes as the locomotive accelerates.
- 3 beeps – Automatically revs up to notch 5 to move off with engine revs twice tickover.
- 4 beeps – Automatically revs up to notch 8 to move off with revs three times tickover. **(Default)**

It is important to tell the soundcard when your loco starts moving and hence when to start revving up. Do this by slowly increasing the throttle until the loco is just about to start to move. Then press the power button on the remote control. This tells the soundcard the voltage at move off.

**Button 8 – Engine Sound.** You can choose from the following:

- 1 beep – English Electric **(British Default)**
- 2 beeps – Modern EMD (Button 5 turbocharger switches on)
- 3 beeps – Classic GM **(US Default)**
- 4 beeps – Alco **(Australasian Default)**
- 5 beeps – Sulzer (Button 5 exhaust reverberation switches on)
- 6 beeps – Railcar.

**Button 9 – The Operating Mode.** There are three operating modes available:

- 1 beep – Indicates manual mode. In this mode all sounds are triggered according to the above settings. The horn will sound for as long as its button is pressed.
- 2 beeps – Indicate simple automatic mode. This is designed for controllers which have no function buttons, as is often the case with track power, or at exhibitions, etc. where you don't want to operate manually. The horn will sound once automatically when the loco moves off and then once more three times a minute when the loco is on motion. A reed switch can be placed under the loco and be connected to the F1 terminal to make the horn sound when the loco passes over a magnet. Another reed switch, connected to the F2 terminal, can be used to trigger the bell which will turn on when crossing a magnet and then off at the next magnet.
- 3 beeps – Indicate American automatic mode. Again this is designed for controllers which have no function buttons, as is often the case with track power, or at exhibitions, etc. where you don't want to operate manually. However, it follows American rules. The horn will sound two long toots when the loco moves off forwards or three short when backing up. If these occur the wrong way around then reverse the leads at the M1/M2 terminals. When the loco stops, a single short toot will indicate brakes on. A reed switch can be placed under the loco and be connected to the F1 terminal to make the horn sound the grade crossing sequence when the loco passes over a magnet.

**Channel up/down buttons– Load Sensitivity.** The soundcard is programmed to make the engine loud when accelerating and softer when coasting and slowing down. The channel up/down buttons change the level of sensitivity as indicated by the number of beeps when pressed. One beep indicates maximum sensitivity. Five beeps sets minimum sensitivity ie. the engine will be loud all the time. The default sensitivity is two and change to one if you want more sensitivity or three or more if the chuff sounds erratic. We recommend one beep for the Crest Revolution controller.

You can change these settings whenever you wish and those changes will be effective immediately.

## 11. RESETTING THE SOUND CARD TO THE FACTORY DEFAULTS

Being able to vary so many settings, you may get into a tangle where the sounds you are hearing don't make sense. In that case, go into run mode (so that the sounds are not muted) and holding down the 0 button on the remote control until you hear five beeps. This will cause the soundcard to reset itself back to its factory defaults. It will not change the country setting.

## 12. OPERATING THE SOUND CARD

When the loco is running, the engine sounds should operate automatically, getting louder when accelerating and softer when slowing down or idle.

Where your controller has function buttons then you can use them as follows:

- Button 1. Sounds the main horn.
- Button 2. Operates the bell or the British horn 2.
- Button 3. Sounds "All aboard" in the US version or the guard's whistle elsewhere.
- Button 4. Sounds the airbrake release.
- Button 6. Starts and stops the engine.

## 13. TROUBLE SHOOTING GUIDE

### THE REMOTE CONTROL WON'T WORK

Start the soundcard, press any button on the remote control and the LED should flash. If it does not flash then the battery probably needs replacing. If the battery is okay then try stretching the battery contact springs and then replace the battery.

If the LED flashes but the soundcard does not respond then the Sony™ coding may have been lost and can be reset as follows.

Refer to the remote control's instructions for resetting the Sony coding. You will probably find a number of codes listed for Sony and will need to try each one until you get to the code which operates the soundcard volume, mute and function buttons correctly. For the Brightstar, hold down the Setup button until the LED comes on and then enter 605. The LED will go off and it is ready for use.

If the remote control still does nothing then the problem may be the infra-red receiver on the loco which must not be painted or obstructed.

---

### I GET NO SOUND AT LOW SPEEDS WHEN USING TRACKPOWER

On trackpower, you may get no sound at low speeds until the track voltage gets up to about nine volts. This indicates that the support battery is flat. Charge the battery by running the loco at half speed for ten minutes.

---

### I GET NO SOUND AT ALL

Press the Mute button on the remote control in case the sound has been accidentally turned off.

Switch the loco off and then on again. When the soundcard starts, the LED should flash once. If not then use a multimeter to check that there is at least nine volts at the B+ and B- terminals. If not then check your wiring in case something has come adrift.

Check that the speaker is connected correctly.

If you are bench testing and there is a light shining on circuit board then this can put the soundcard into factory programming mode and stop the sound. In that case, the yellow LED next to the F1 terminal will stay on. You can fix this by covering the IR receiver on the soundcard and on the flying lead, if fitted.

---

### THE SOUND CARD MAKES A CLICKING NOISE OR SHUTS DOWN

This most often occurs when the horn is sounded. It is caused by the soundcard restarting because there is insufficient voltage in the track or the battery to sustain the volume setting. Recharge the battery.

---

### WHEN INSTALLED IN A LOCO, THE LOCO AND SOUND STOP INTERMITTENTLY AND I HAVE TO RESET THE CONTROLLER TO GET IT GOING AGAIN

The soundcard maximum output is 1.5 amps. If this is exceeded as a result of a short circuit, a heavy load and/or high volume settings then the soundcard will shut down. Also, if the soundcard is installed in a very confined space and is run for a prolonged period at high power then it can overheat and switch itself off while it cools down.

---

### HOW TO RESET YOUR SOUND CARD

A time may come when you have been adjusting the sound and you want to start again. This can be achieved by resetting the soundcard back to the settings when it left the factory. You can do this by pressing the 0 button on the remote control and hold it down for three seconds. The soundcard will beep five times when the reset is complete.

## 14. USING AN EXTERNAL AMPLIFIER FOR RIDE ON RAILWAY LOCOMOTIVES

When used in 5 inch and 7¼ inch ride on railways there is a lot of environmental noise. The output of the soundcard alone is not sufficient for these environments and an external amplifier needs to be used. The wiring diagram overleaf shows how the soundcard can be interfaced to a commercial stereo amplifier in a loco with 24v motors powered by two 12 V batteries.

Note that the soundcard can handle a maximum of 24 volts DC. A battery which is labelled as 24 volts will typically output 28 volts when fully charged and will therefore damage the soundcard if connected directly. The two 10K resistors on the M1/M2 terminals keep the voltage down to 24v.



A 2x15 watt stereo amplifier is suitable. Other amplifiers may require the 100Ω resistor to be changed. If the output volume is too low then raise the value of the 100Ω resistor.

A single speaker can be used on the right output or two speakers on the left and right outputs.

Any of the five functions can be used by means of a pushbutton between the function terminal and ground. The sound functions available are horn, bell, "All aboard", airbrake release and engine start/stop. Only the horn wiring is shown in the diagram.

The installation can be made more robust by enclosing the soundcard, capacitor and two resistors into a plastic project box as shown in the diagram.

The whole can then be fixed to the top of the amplifier using silicon. Select a speaker which matches the impedance and power output of the amplifier. It is also important to make a soundbox which is an airtight fit to the back of the speaker. This will improve both volume and sound quality.

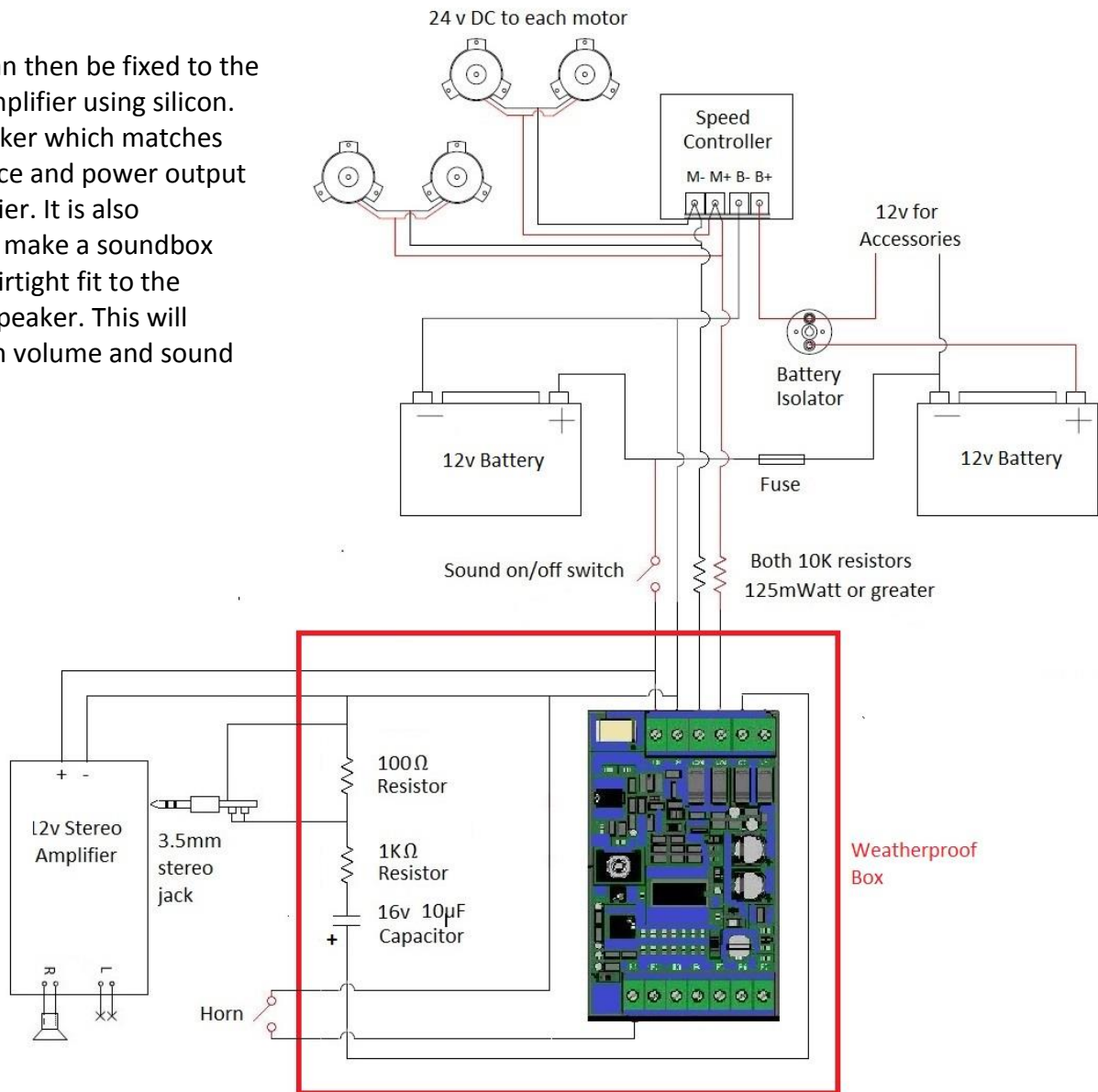

PLC009 Diesel Instructions US.doc 31/3/19 Version 18E

For more information, please visit the web site at [www.mylocosound.com](http://www.mylocosound.com) or e-mail [sales@mylocosound.com](mailto:sales@mylocosound.com).

Copyright © 2013-9 MyLocoSound Pty. Ltd.

Remote Control	Radio Control		US Defaults shown in bold
<b>Power</b>		Set Start Voltage for Rev Up	
<b>VOL up/down</b>		Change Volume of active sound	
<b>CH up/down</b>		Change Sound	Horn Tone when horn sounding
			Engine tickover rate when static
			Engine rev rate when moving
<b>Mute</b>		Sound on/off	
<b>Button 1</b>	<b>F1</b>	Whistle	Seven to select from
<b>Button 2</b>	<b>F2</b>	Bell	1 beep Manual on/off
			2 beeps Automatic timed ring when F2 is triggered.
			3 beeps <b>Rings when motor below 4 volts</b>
			4 beeps Rings when motor below 8 volts
			5 beeps Rings when motor below 12 volts
			6 beeps Single rings
			7 beeps Short horn
<b>Button 3</b>	<b>F3</b>	The Guard	1 beep Guard's whistle
			2 beeps <b>"All aboard"</b>
			3 beeps <b>"All aboard"</b> followed by guard's whistle
<b>Button 4</b>	<b>F4</b>	Brake release/squeal	1 beep <b>Not required</b>
			2 beeps Automatic brake squeal
			3 beeps Automatic brake squeal and release
<b>Button 5</b>	<b>F5</b>	Turbocharger and exhaust	1 beep <b>Off</b>
			2 beeps Turbocharger on
			3 beeps Exhaust reverberation on
<b>Button 6</b>	<b>F6</b>	Engine start/stop	1 beep <b>Manual</b>
			2 beeps Automatic
<b>Button 7</b>	<b>F7</b>	Engine Type	1 beep Engine revs up steadily with throttle
			2 beeps Mechanical gear changes
			3 beeps Revs up to notch 5
			4 beeps <b>Revs up to notch 8</b>
<b>Button 8</b>		Engine Sound	1 beep English Electric
			2 beeps Modern EMD
			3 beeps <b>Classic GM</b>
			4 beeps Alco
			5 beeps Sulzer
			6 beeps Railcar
<b>Button 9</b>		Control Mode	1 beep <b>Manual</b>
			2 beeps Auto horn every 20 secs
			3 beeps Auto horn with Track Magnets
<b>Hold down</b>			5 beeps Re-sets sounds to factory defaults